

COVER - TOP VIEW

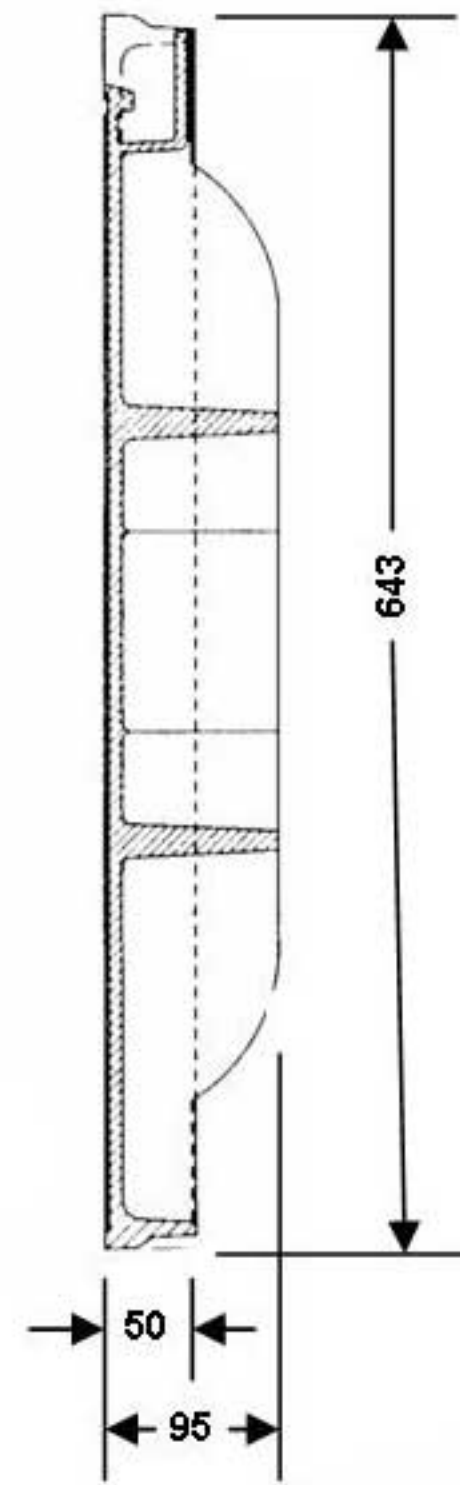

SECTION 'A-A'

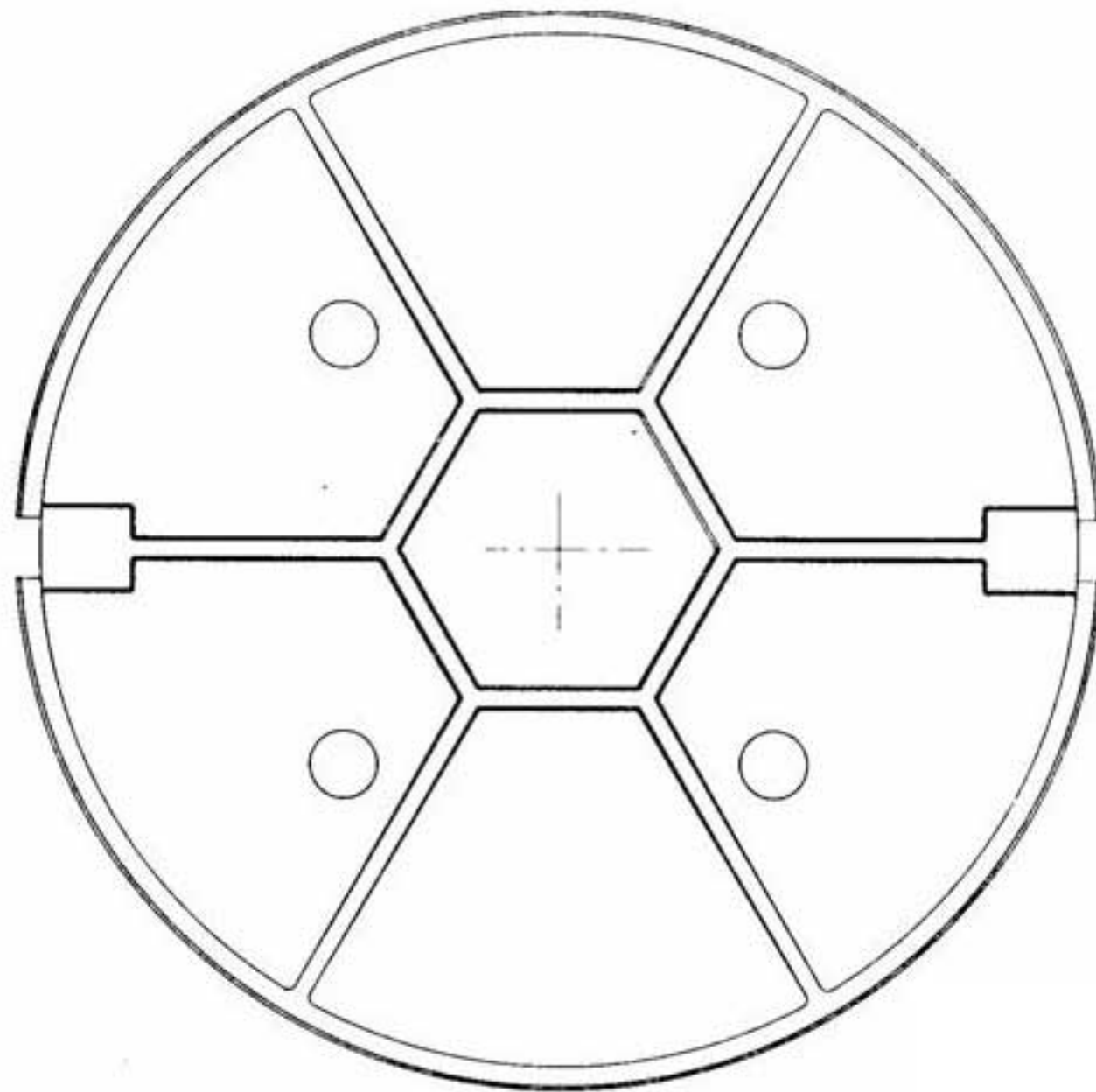

COVER - BOTTOM VIEW

MATERIAL SPECIFICATIONS:
 DUCTILE IRON GRADE 80-60-03,
 BEARING SURFACE SHALL BE
 MACHINED TO PREVENT
 ROCKING

SPECIFICATIONS:

THE CASTINGS SHALL BE TRUE TO PATTERN AND FREE FROM CRACKS, GAS HOLES, FLAWS AND EXCESSIVE SHRINKAGE. SURFACES OF THE CASTINGS SHALL BE FREE FROM BURNT ON SAND AND SHALL BE REASONABLY SMOOTH. RUNNERS, RISERS, FINS AND OTHER CAST ON PIECES SHALL BE REMOVED. IN OTHER RESPECT THE CASTINGS SHALL CONFORM TO WHATEVER POINTS MAY BE AGREED UPON BETWEEN THE MANUFACTURER AND THE ENGINEER. UPON REQUEST OF THE ENGINEER THE MANUFACTURER SHALL BE PREPARED TO CERTIFY THAT HIS PRODUCT CONFORMS TO THE REQUIREMENTS OF A.S.T.M. DESIGNATION A-48.



**FLOATING FRAME TYPE
 MANHOLE COVER**

NF-80